

FOR SERIES II and SERIES III, 88"

FITTING INSTRUCTIONS FOR LAND ROVER MANUAL FREE-WHEELING HUB

Please hand to customer after fitting for
his careful perusal

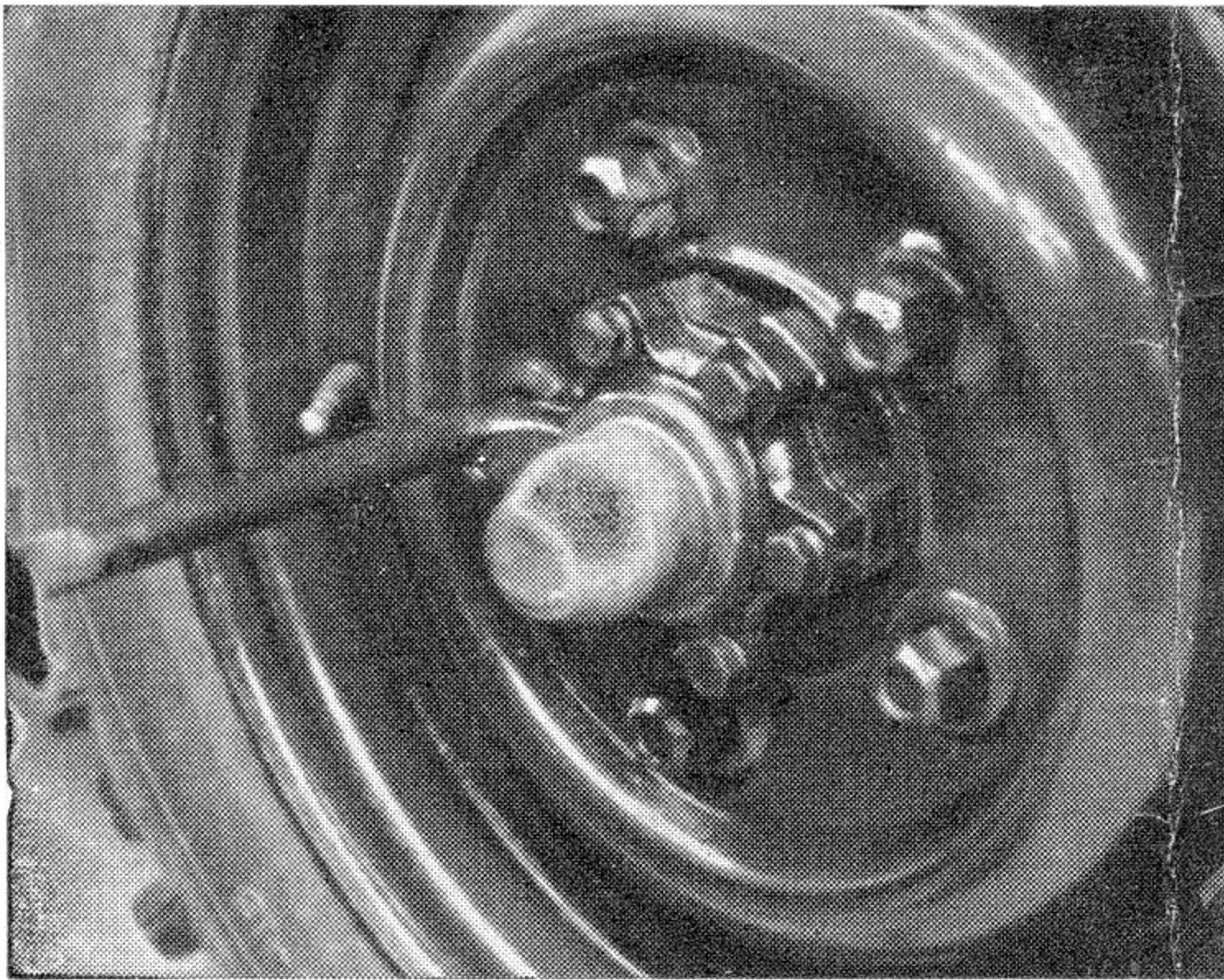

1. Remove the oil cap covering the extension of the front stub axle.

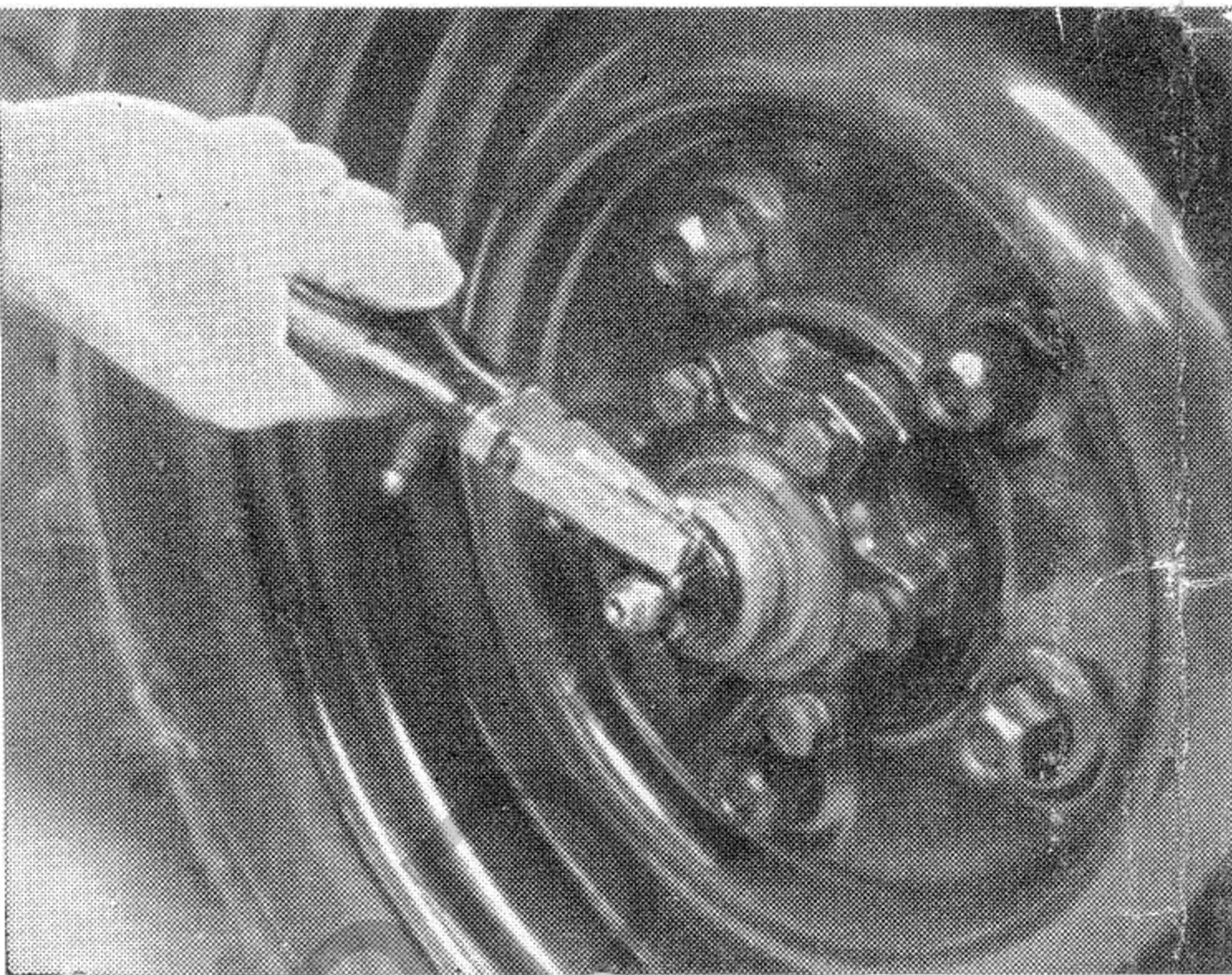

2. Remove the cotter pin securing the castellated nut on the extension of the stub axle.

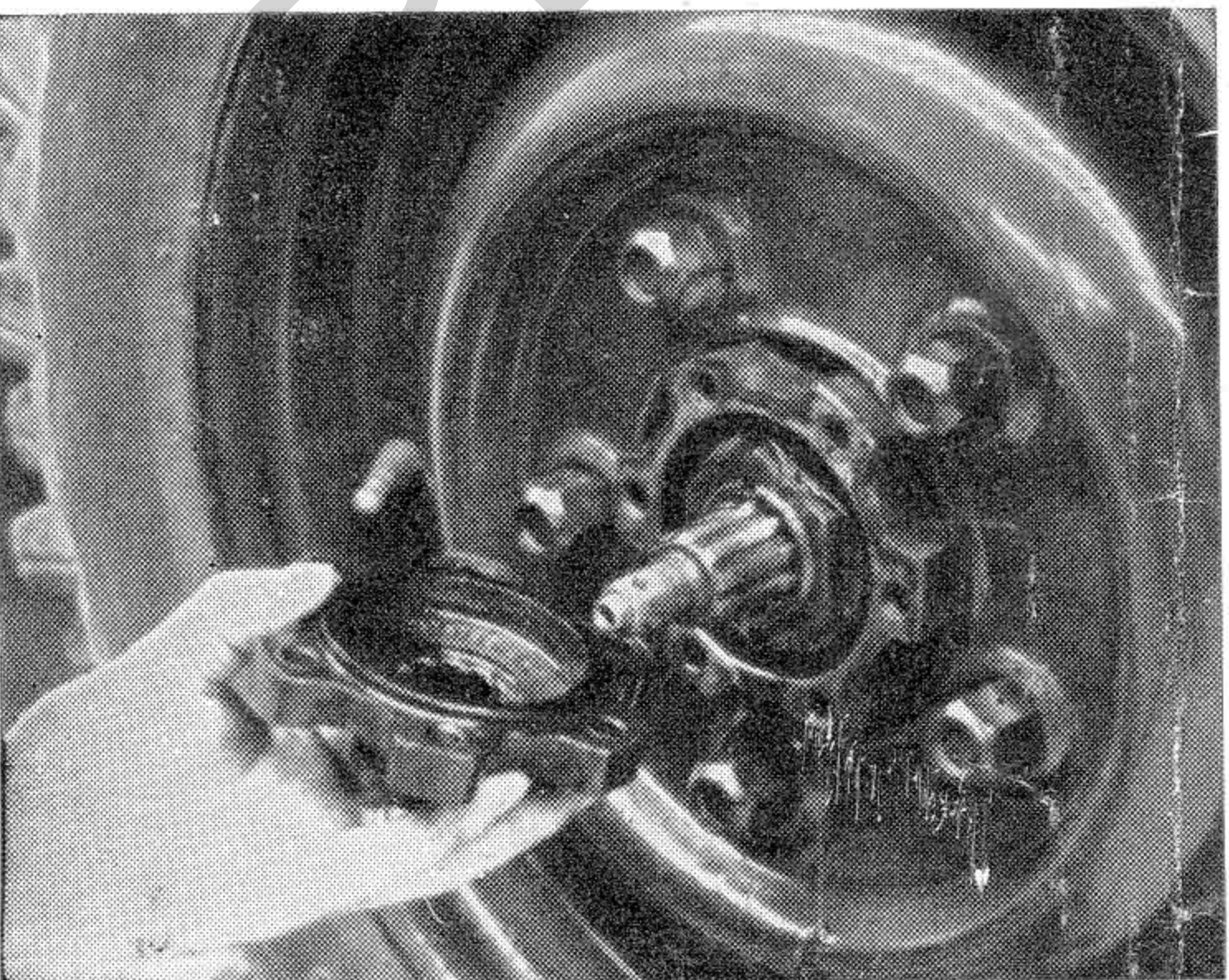

3. Remove the 6 bolts securing the driving 'star' in position.

4. Remove the driving 'star' (**this is not required but with the bolts should be retained in case the vehicle is sold and the Free-wheeling Hubs removed**).

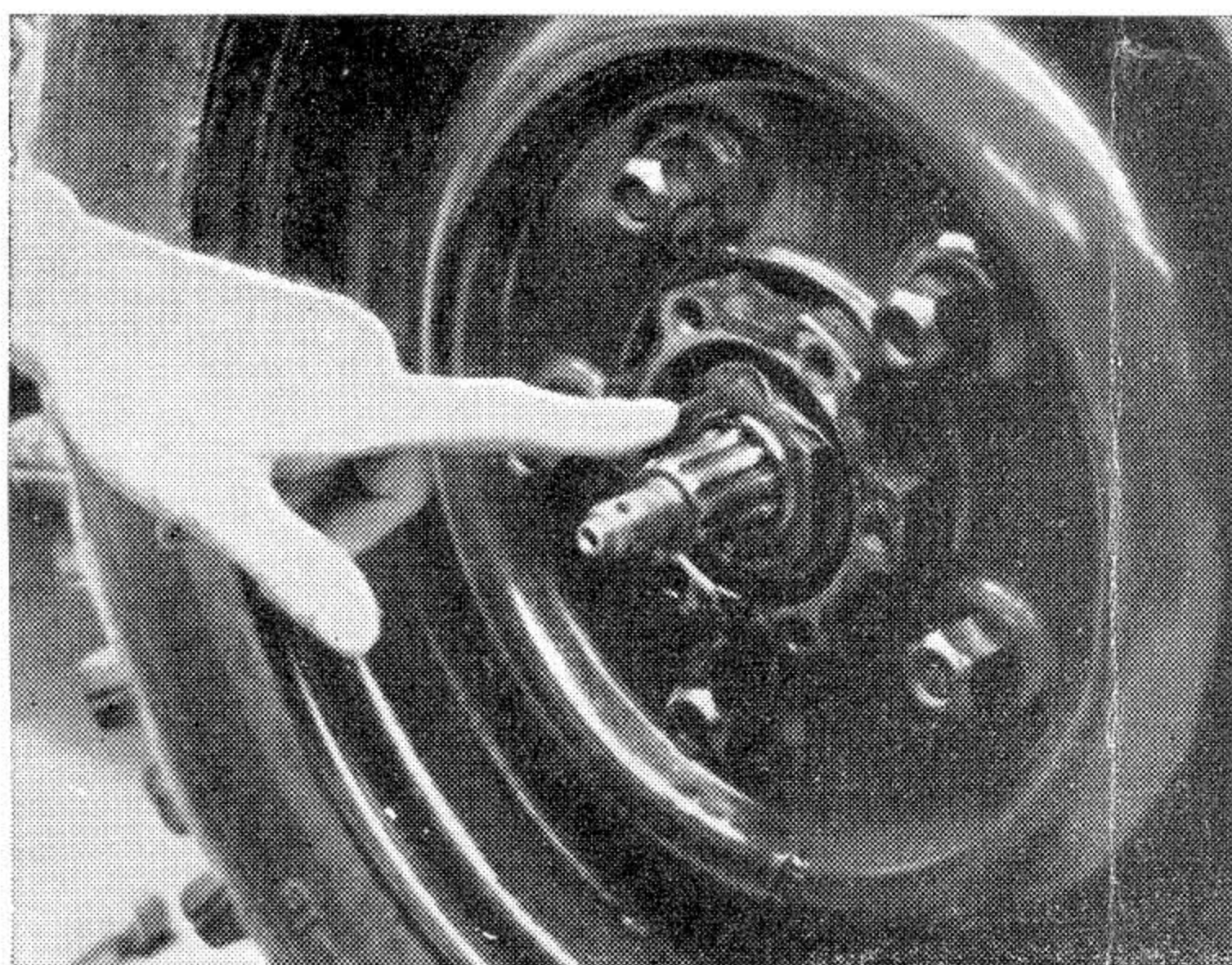

5. Jack up the vehicle at the front and check whether there is any end float on the wheel bearings. If so, correct before proceeding any further. (The Land Rover Manual should be referred to — operation F16 in the Series 2 manual.) The end float is removed with inner hub nut and lock-nut. As a safeguard this should be checked again after locking the lock-nut in position.

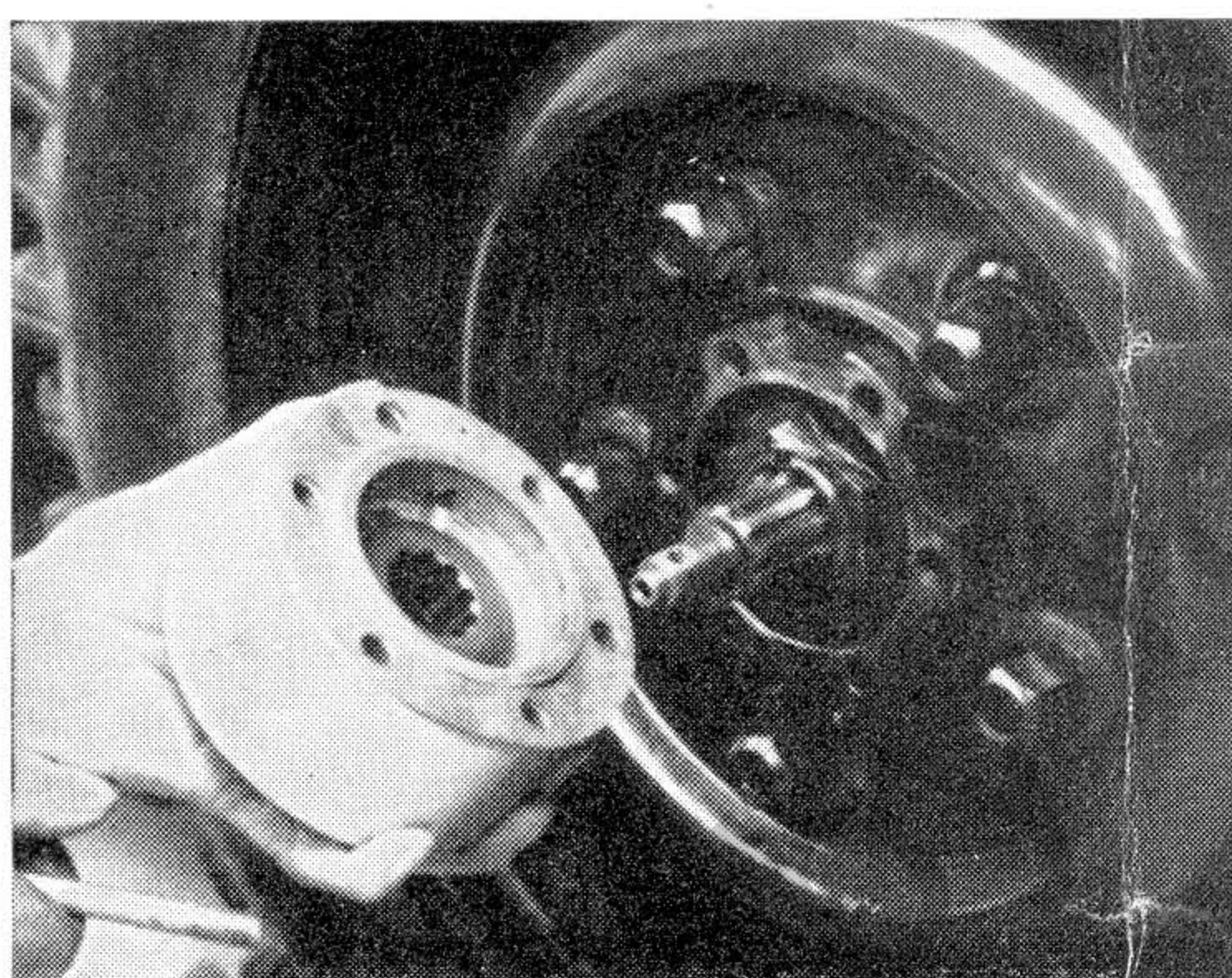

6. Fix the new paper gasket to the flanged face of the free-wheeling hub main unit with jointing compound or grease. Check that the pawls are fully engaged. Locate the centre gear of the main unit on to the splined stub axle, push home and loosely screw in one bolt to hold it in position.

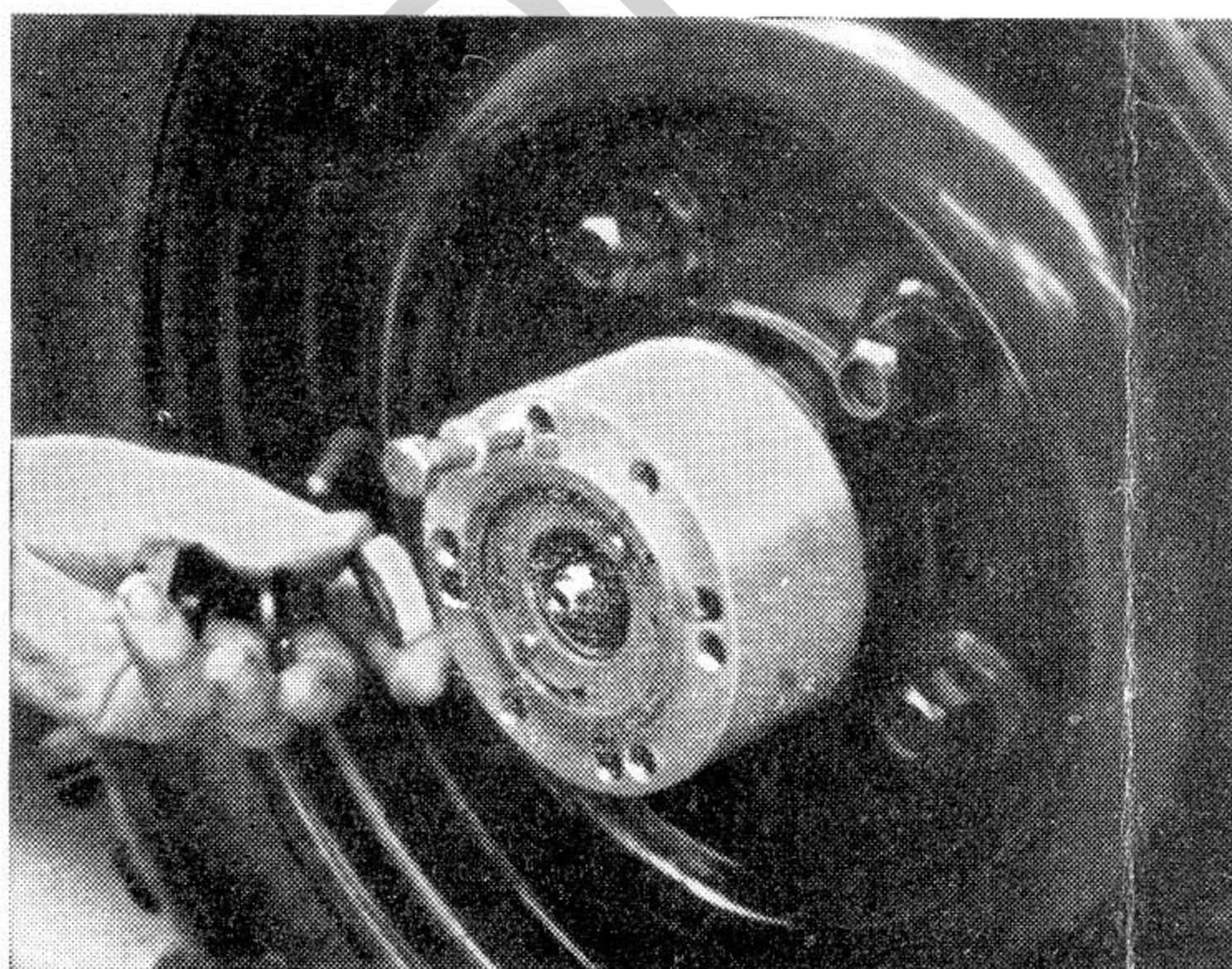

7. Fit the new rubber and felt oil seal with washer on the splined stub axle and screw on the original castellated nut. **DO NOT OVERTIGHTEN**, i.e., first tighten the nut and turn back to the nearest position for the cotter pin to be inserted and spread.

8. Fix the paper gasket in position on the body — make sure the slots in the gasket are in line with the pawl slots in the main body.

**IMPORTANT
ENSURE THAT IF JOINTING
COMPOUND IS USED IT
DOES NOT EXUDE INTO
THE MECHANISM OR
FAULTY OPERATION WILL
RESULT.**

9. Pick up the cover assembly and check that the arrow points to fixed (as normally supplied and packed) if this is not so turn Hex: head with spanner until this position is reached. On the Hub body and cover there are two red dots, these dots must be placed adjacent to each other for final assembly (this is essential as the Hubs are manufactured with two recesses on the actuating disc, one smaller than the other, which fit pins of appropriate sizes on the lock cam, if this were not so arranged the Hubs could be assembled with 'FREE' or 'FIXED' in the wrong position). Screw in one bolt followed by the others and tighten in opposing pairs (This should be done with a torque spanner — 28 lbs. ft.).

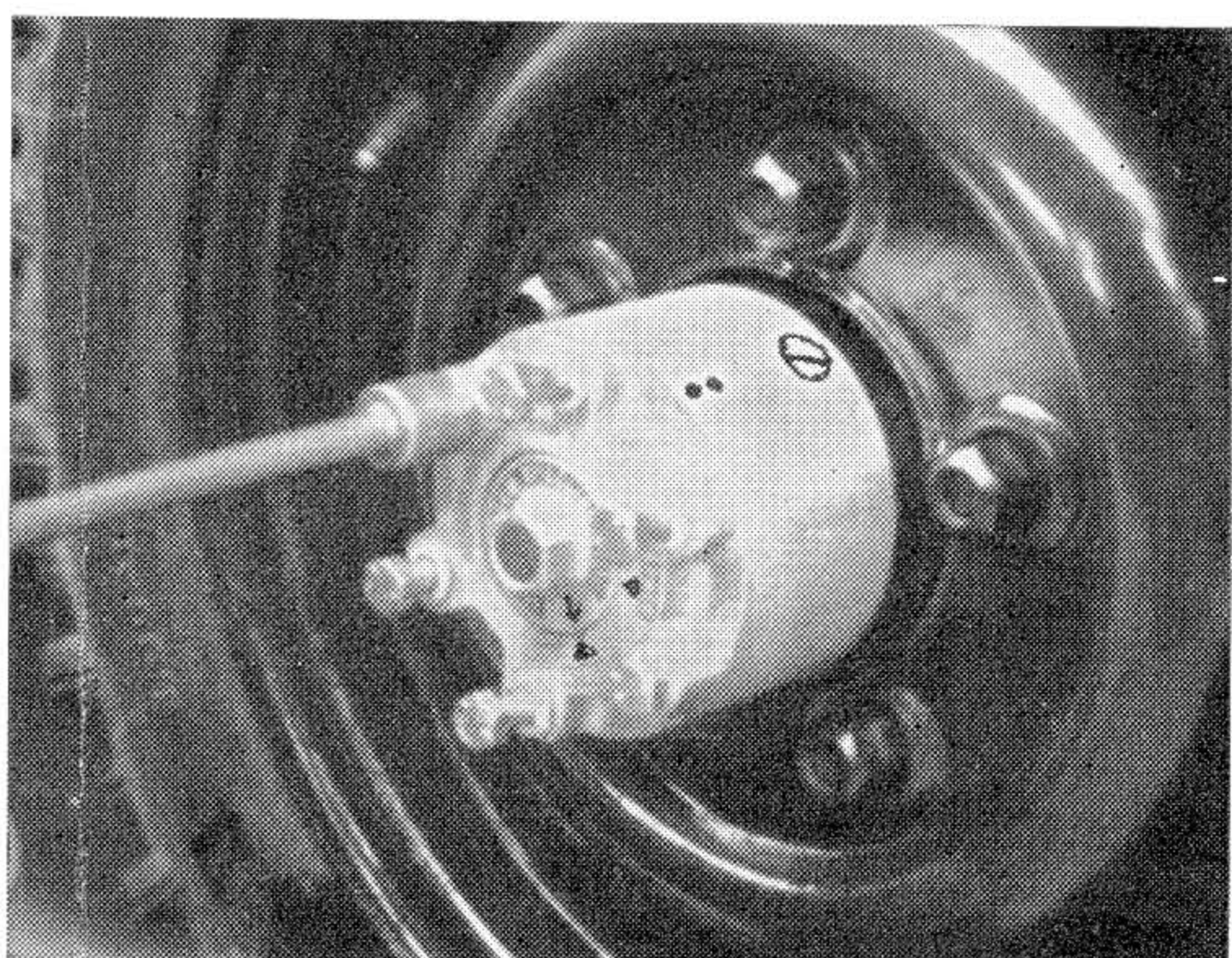
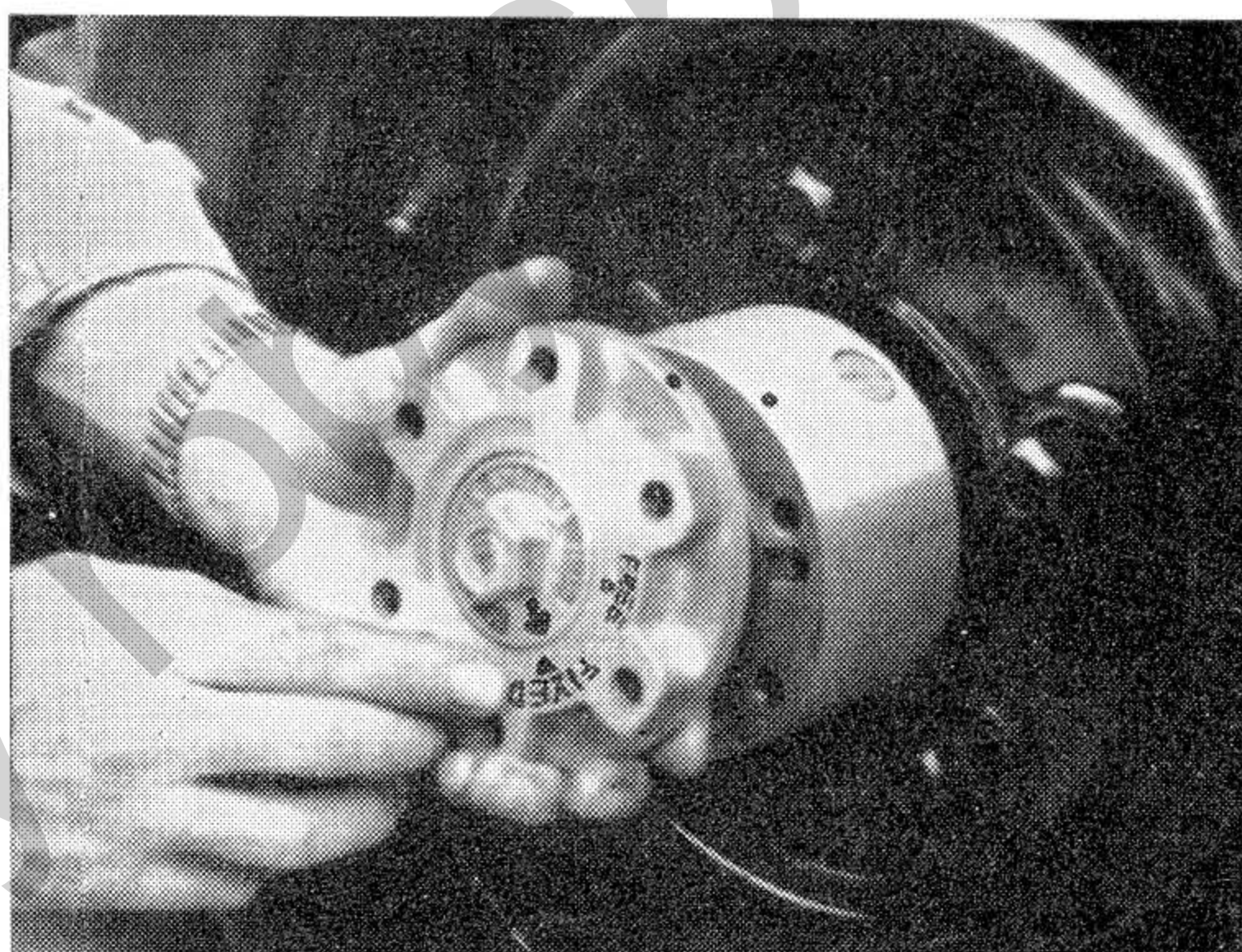
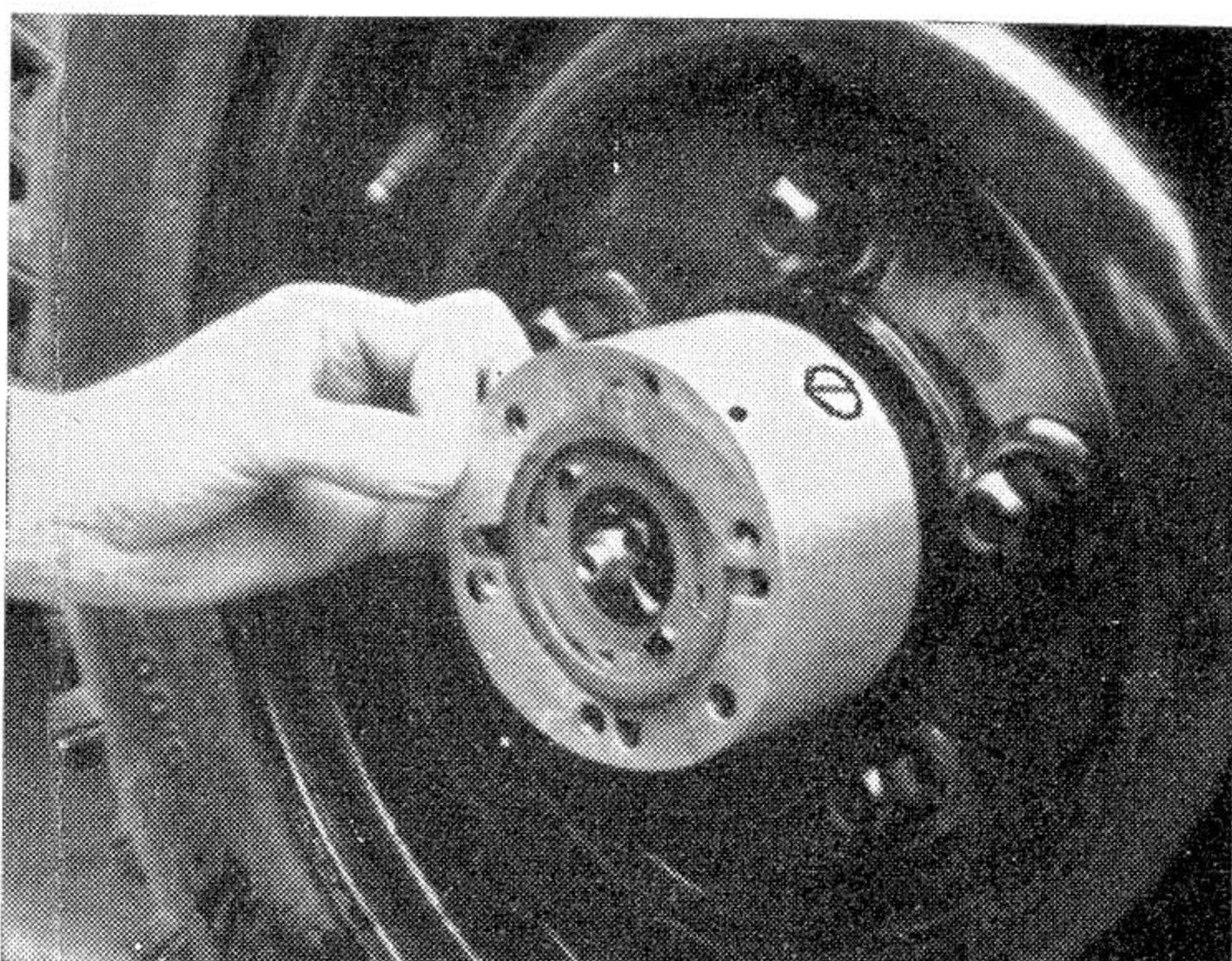

10. The fitting is now complete and to check operation rotate the wheel by hand and verify that it is fixed to the transmission. Then turn the nut in the centre of the Hub to 'FREE' — (the action is designed to be somewhat stiff to avoid the possibility of oil or grease leaking) check that the wheel is free from the transmission. Set to fixed once more and rotate the wheel by hand slowly, after a few degrees of turn the pawls will be heard 'clicking' into position and the wheel will be once again fixed.
11. The Hubs are cleaned and greased at the factory. No further oil or grease is advised until you service your vehicle in the normal way.
12. Repeat the assembly instructions in respect of the other front wheel and the vehicle is ready for use.
13. Fasten transparent warning notice to windscreen.
 - a. **Hubs in 'Free' position.** (Economy driving).
Do not engage four-wheel drive whilst vehicle is moving. Engagement will immediately accelerate the front transmission from rest to road speed and could cause damage. Because your front wheels are not connected to the transmission there is no point in selecting four-wheel drive; furthermore all the low ratio torque would be applied to the rear wheels only, possibly causing damage.
 - b. **Hubs in 'Fixed' position.** (Four-wheel driving).
Your front wheels are connected to the transmission and as long as they are kept in the fixed position you can select four-wheel drive whenever required.
14. You should not attempt to dismantle the Hub as it is a sealed unit.
15. The Hubs require no maintenance apart from occasional grease or suitable oil in the same way as the standard vehicle.
16. **Note when the Hubs are set from FREE to FIXED turn the nut fully clockwise and then turn back until the arrows are correctly aligned, and make sure the vehicle is not run with only one hub fixed.**
17. Retain separate parts list for your future reference.

Manufactured by:

FAIREY WINCHES LTD

142-148 Plymouth Road, Tavistock
Devon, England, PL19 9DR

Telephone Tavistock 2345/6

Telex 45324

PDF by robby65to

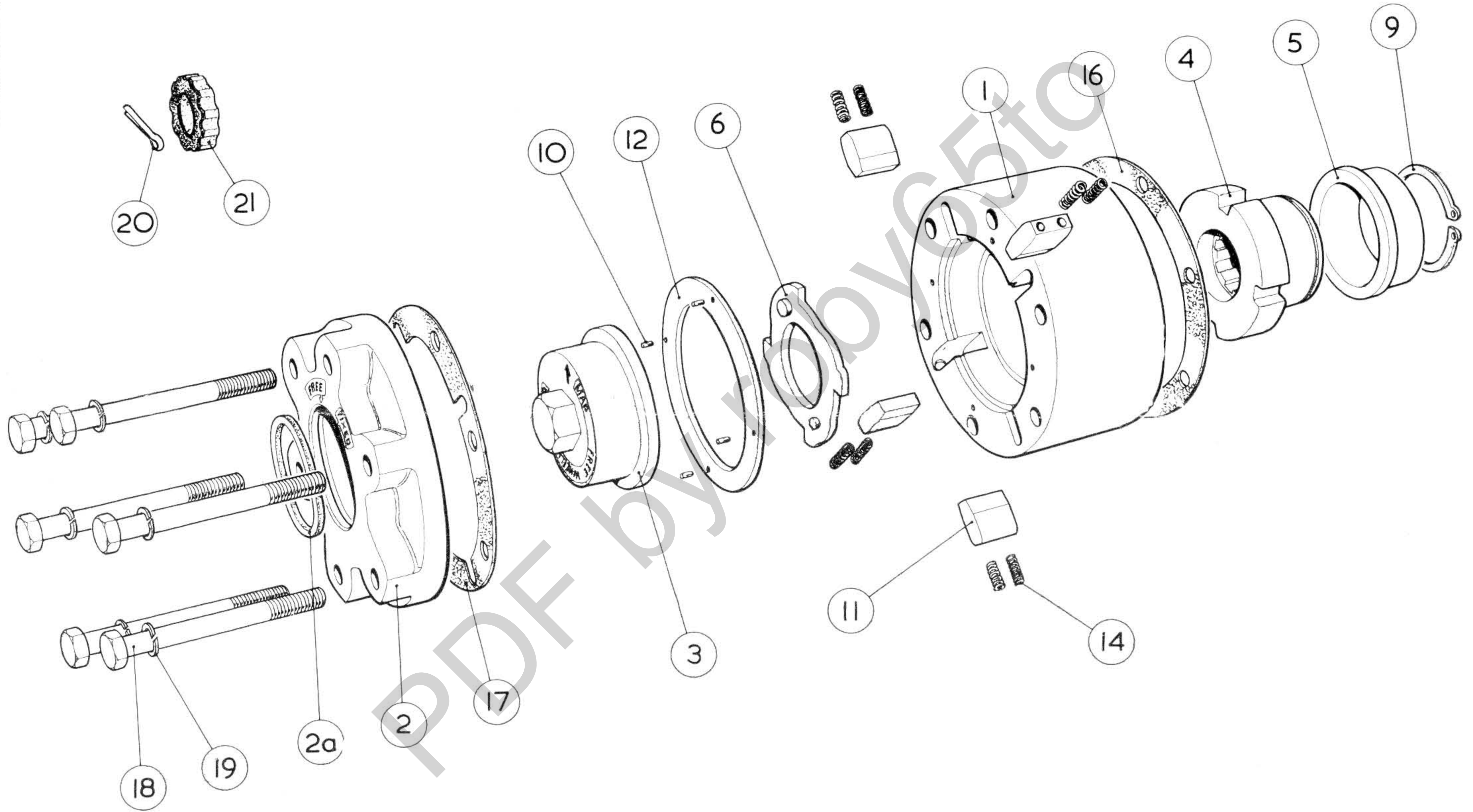

PARTS LIST

FAIREY WINCHES LIMITED

LAND ROVER Free-wheeling Hub

Part Number

536603/1 Body Casting.
536603/2 Cover Casting.
536603/2a Actuating Disc Dust and Grease Seal combined.
536603/3 Actuating Disc.
536603/4 Drive Gear.
536603/5 Drive Gear Bush.
536603/6 Lock Cam.
536603/9 Circlip.

Part Number

536603/10 Drive Pins.
536603/11 Pawl.
536603/12 Pawl Retaining Ring.
536603/14 Pawl Spring.
536603/16 Rear Oil Gasket.
536603/17 Front Oil Gasket.
536603/18 Bolts.
536603/19 Spring Washers.
536603/20 Cotter Pin.
536603/21 Splined Seal.