

LAND ROVER

Air cleaner incorporates one-way drain valve to prevent accumulation of water/dirt while wading.

Thermac device sited on air intake diverts warm air from exhaust region for quick warm-up period thus enhancing economy.

Viscous - coupled fan for enhanced economy and quieter running.

Sealed heavy-duty cooling system.

Engine designed to run between -30°C and +40°C.

High output (45 amp) alternator to cope with large electrical loads without risk of draining battery.

Lightweight, compact all-aluminium engine run on test bed for 1 hour.

Restyled front end for easy access.

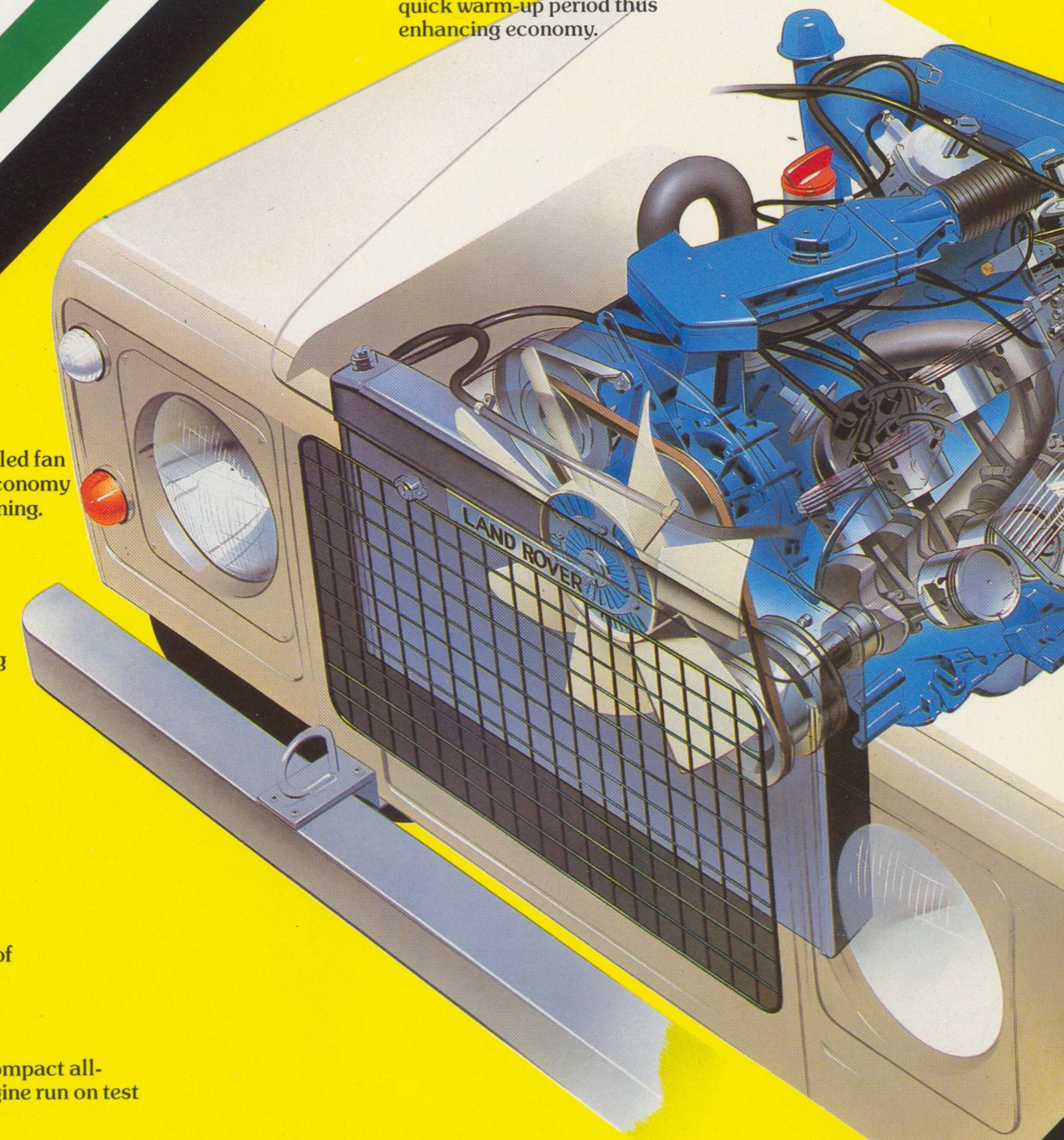

NEW

The V8 Station Wagon

For personnel transport under any type of conditions, the Station Wagon version of the new V8 is unbeatable. Seating up to 12 people in remarkable comfort, its spaciousness makes light of the longest journey. Its robust suspension enables it to cope with prolonged trips over rough country, while its high cruising speed swallows up mile after mile of surfaced road.

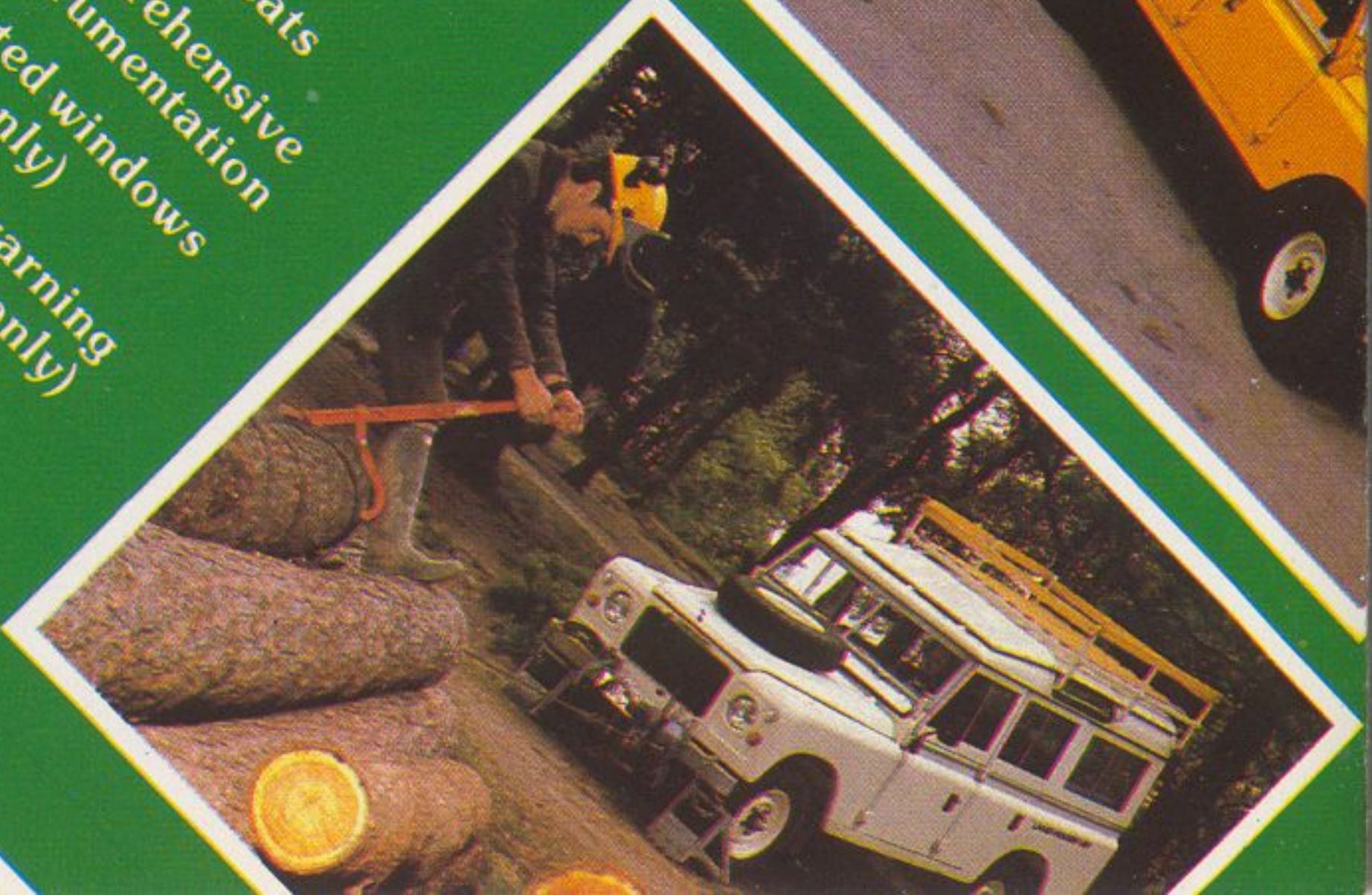
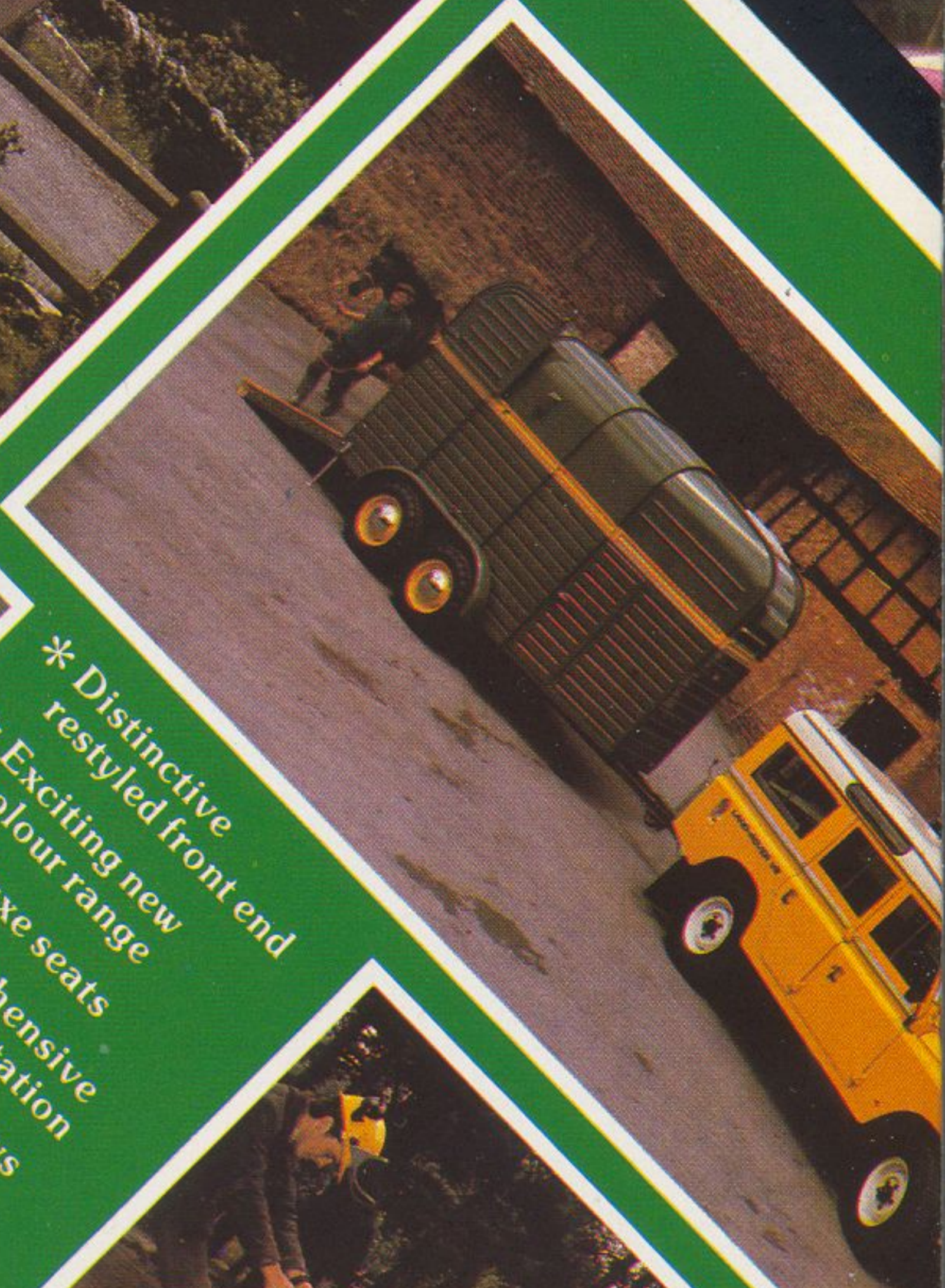
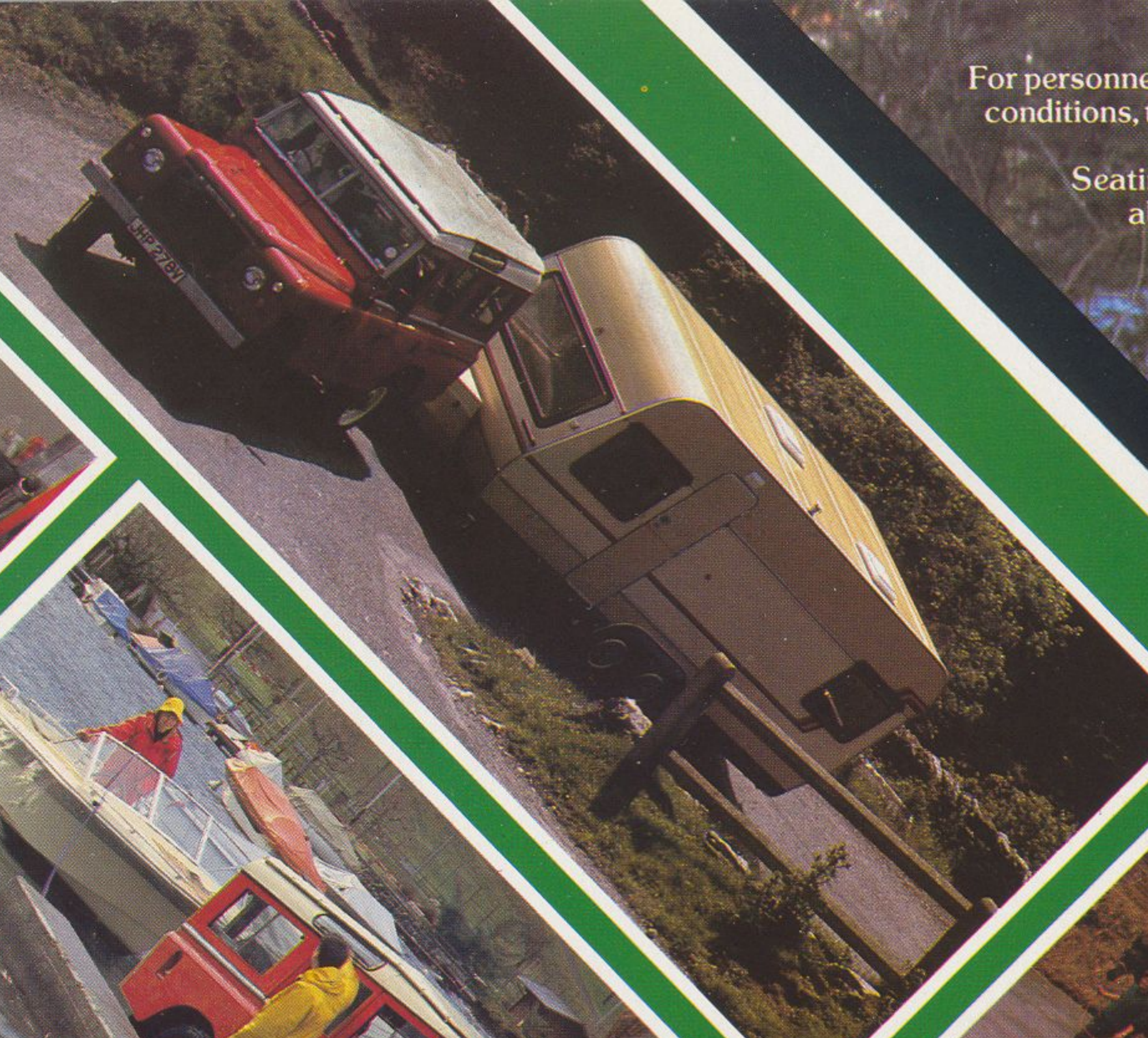
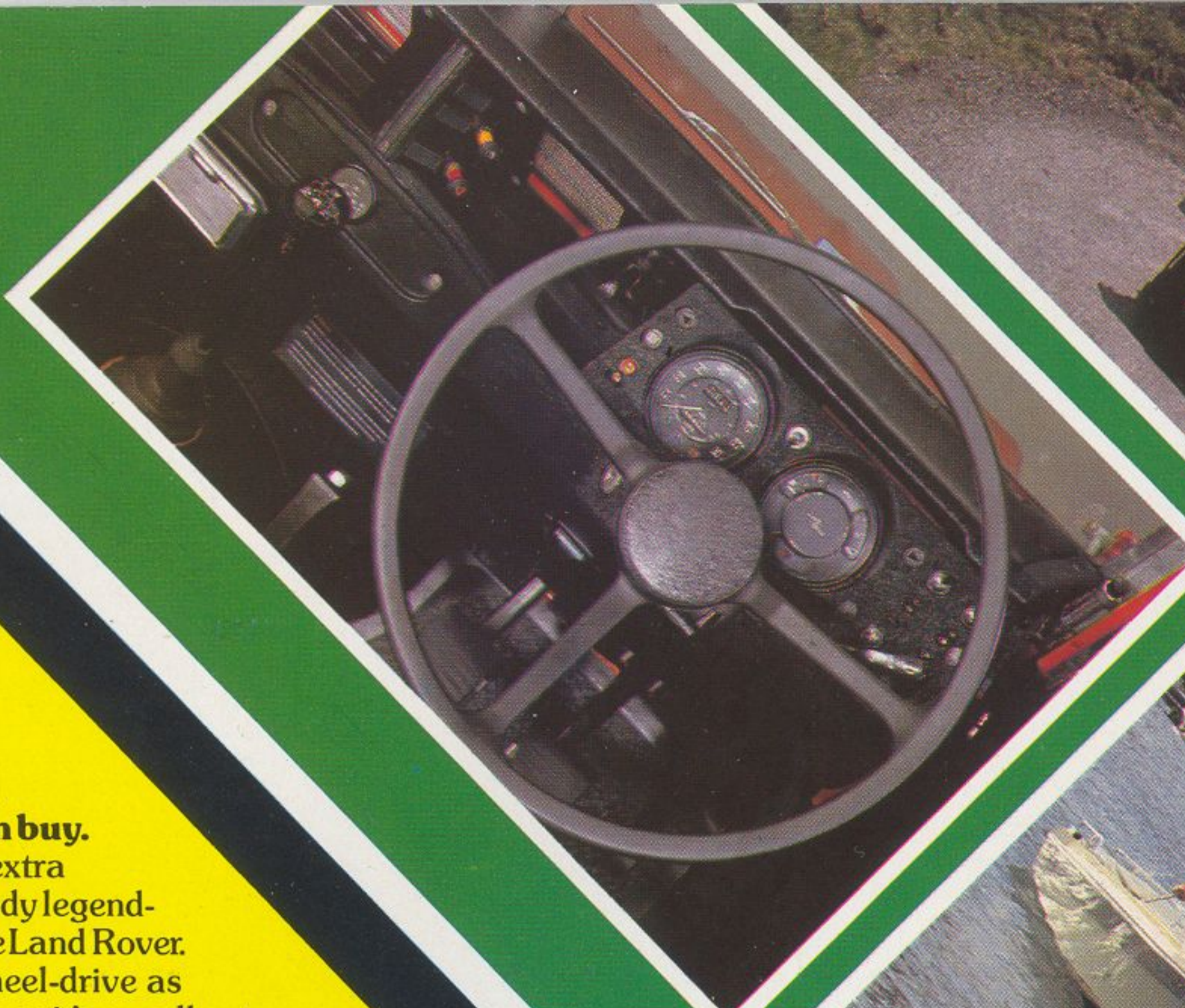

The most powerful Land-Rover you can buy.

The new V8 adds an extra dimension to the already legendary performance of the Land Rover. With permanent 4 wheel-drive as used in the Range Rover, it's equally at home on or off the road, and built to tackle the toughest terrain. Its lightweight aluminium 3500cc engine delivers exceptionally high torque at low revs which means more pulling power. A heavy duty 4-speed gearbox with transfer box offers a ratio for every situation.

In addition to permanent 4 wheel-drive, when the going gets really rough the centre differential can be locked for even greater traction.

The 3500cc engine tuned for maximum efficiency in the V8 Land Rover gives a top speed of over 80 mph (128 kph) and the ability to climb gradients as steep as 45° (1 in 1). Engine power is produced smoothly, quietly and with minimal effort. This results in better off road performance, better towing ability, less gear changing and enhances economy of operation in certain conditions.

Built and designed to go anywhere.

With an all-aluminium body, the new V8 offers an exceptional power/weight ratio. And the aluminium construction of its engine, producing 90bhp, is 60% lighter than its equivalent in cast iron. Within its completely redesigned engine compartment, all service points offer outstanding ease of access.

The ignition components are located at the highest points so that, even when the V8 is wading through water, all its essential electrical circuits stay safely dry. In dusty or arid conditions, atmospheric pollutants are filtered out while still affording optimum airflow to the carburettors. And the traditional go-anywhere character of the Land Rover is reflected in the new V8 in the immense strength of its box section ladder-type chassis and its suspension. As well as being resistant to corrosion, its light aluminium body panels, being bolted on wherever possible, offer easy replacement in the event of accident damage. It is this ruggedness and reliability that has made Land Rover the choice for over 30 years of armies, police and all operators whose work involves off-road conditions. And, in the new V8, these virtues are now embodied in the most powerful Land Rover you can buy.

- * Distinctive restyled front end
- * Exciting new colour range
- * De luxe seats
- * Comprehensive instrumentation
- * Tinted windows (SW only)
- * Hazard warning lights (SW only)

LAND



RR

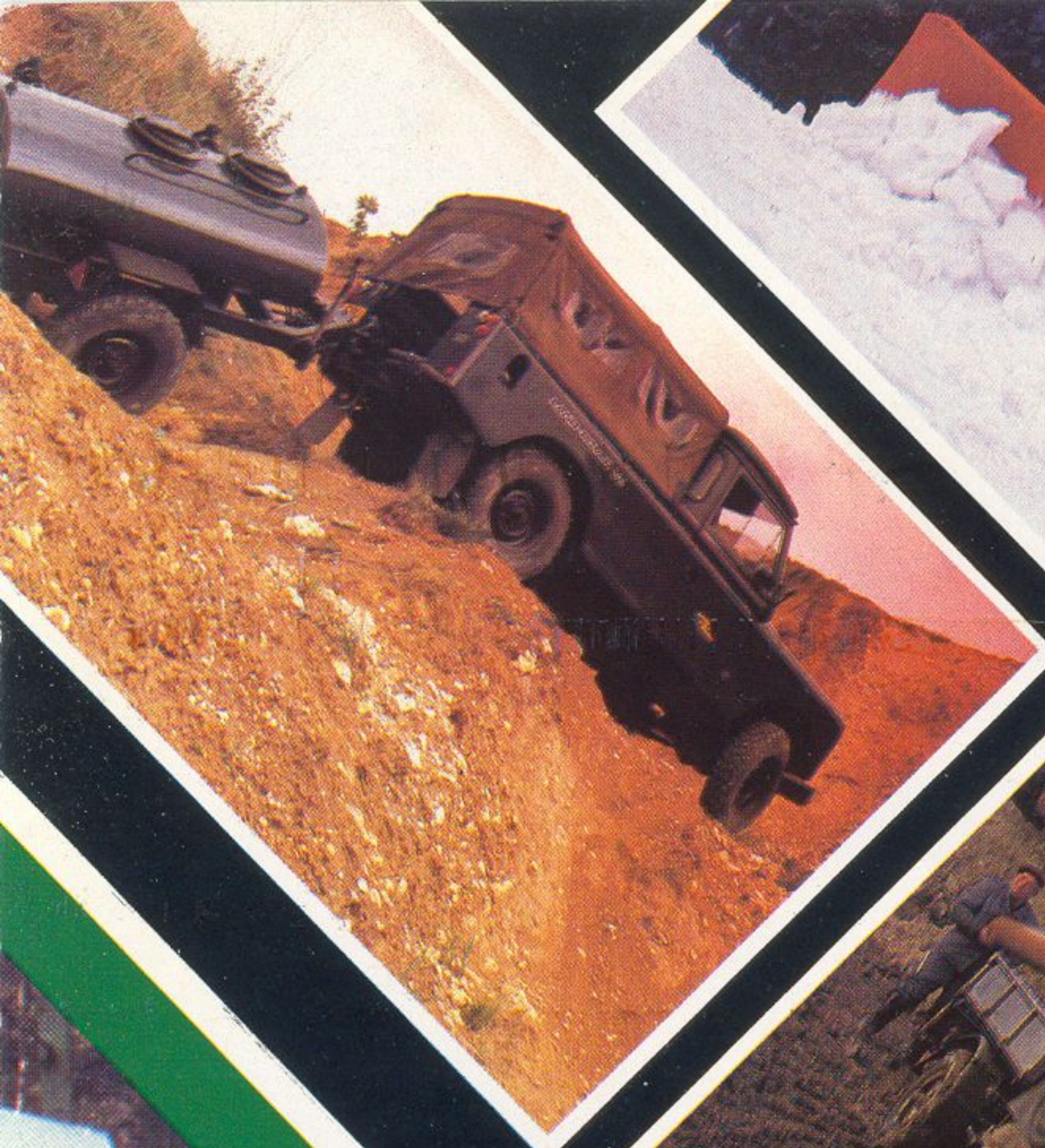

- * Permanent 4 wheel-drive
- * Differential lock
- * Servo assisted dual-line brakes
- * Lifting/towing rings, front and rear
- * Rear fog lamp
- * Astrolan wax coating

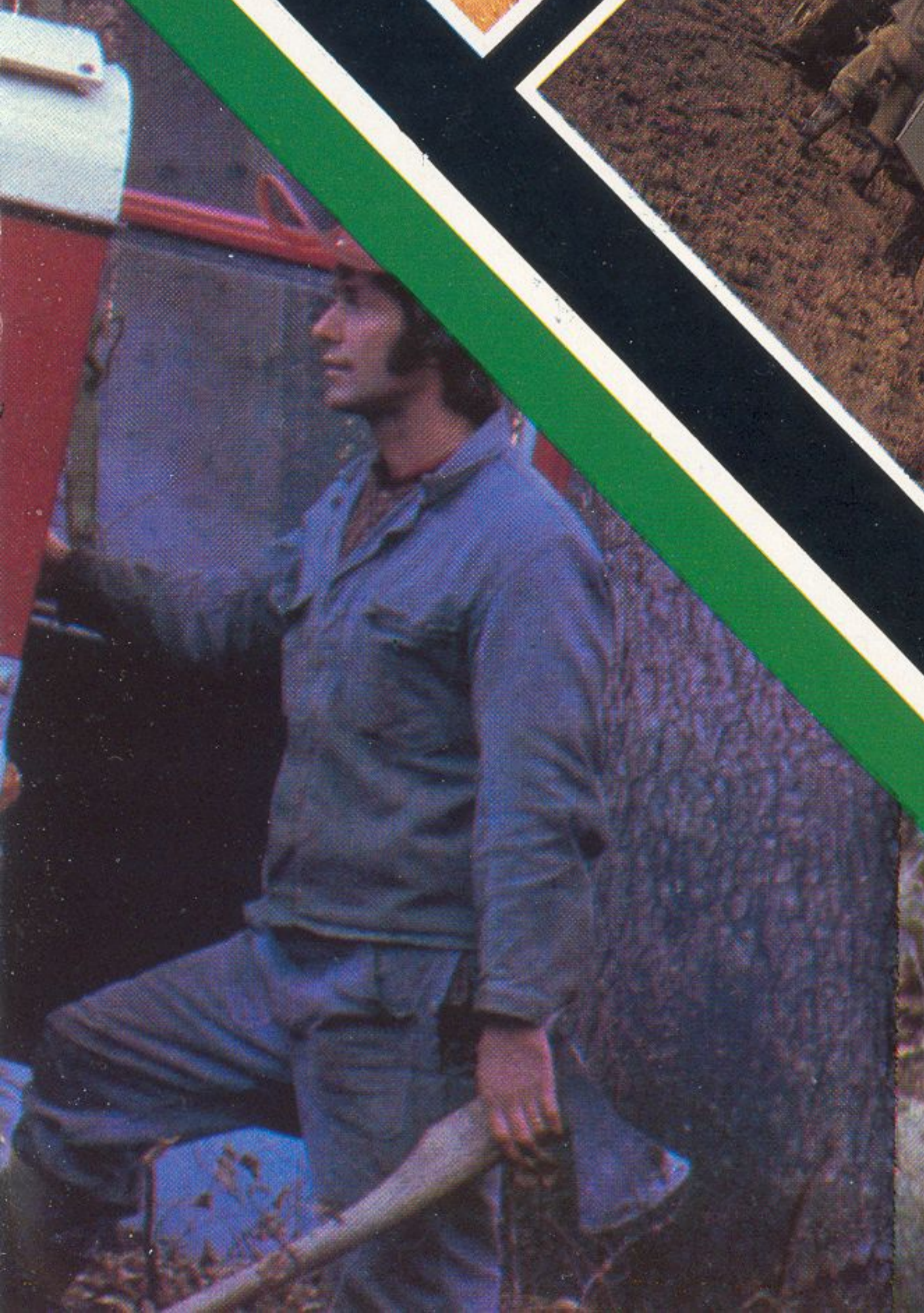



The V8 Pick-up

The remarkable torque and towing power of the new V8 make the pick-up version the obvious choice for every type of agricultural or commercial operation. In a matter of seconds, you can hitch up almost any type of trailer or mobile plant. And the pick-up is available in truck cab, full length hard top and full- or ¾-length canvas hood. To the power of the new Land Rover V8, the pick-up version adds the versatility that has made it foremost throughout the world of industry.

Carburation and lubrication system arranged so engine is never starved of petrol/oil during violent manoeuvres.

Low compression ratio allows use of fuel down to 85 octane.

Self-adjusting tappets for quieter running.

Electical system PVC insulated thus giving protection against petrol, oil, moisture or fungal attack.

Crankshaft vibration damper ensures smoother running.

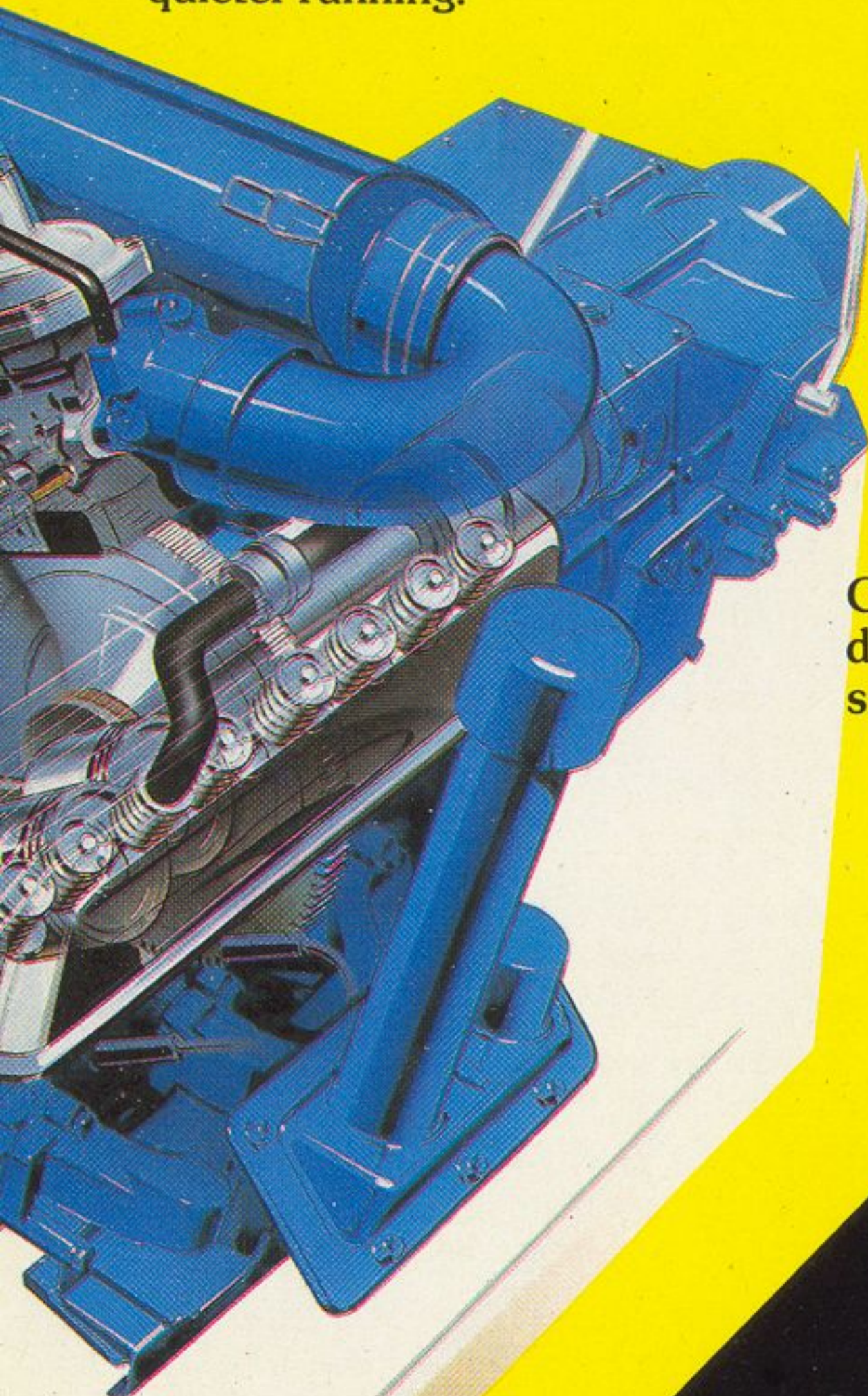

BL Cars Limited is constantly seeking ways to improve the specification, design and production of its vehicles and alterations take place continually. While every effort is made to produce up-to-date literature, this Brochure should not be regarded as an infallible guide to current specification, nor does it constitute an offer for the sale of any particular vehicle. Distributors and Dealers are not agents of BL Cars Limited and have absolutely no authority to bind BL Cars Limited by any express or implied undertaking or representation.

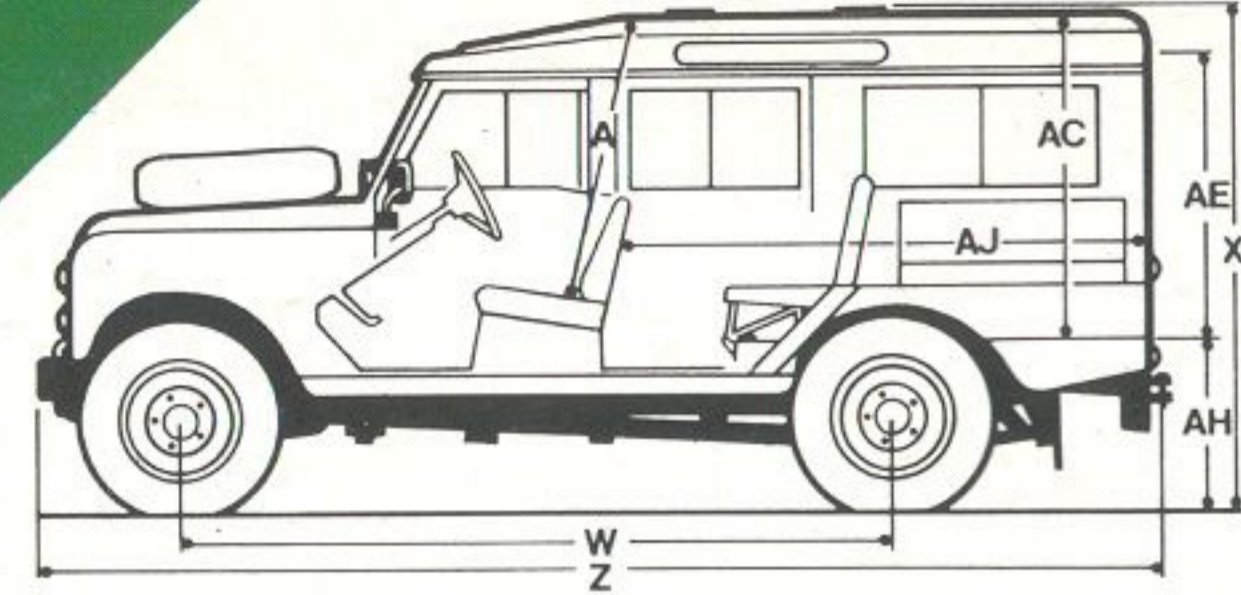

Station Wagon

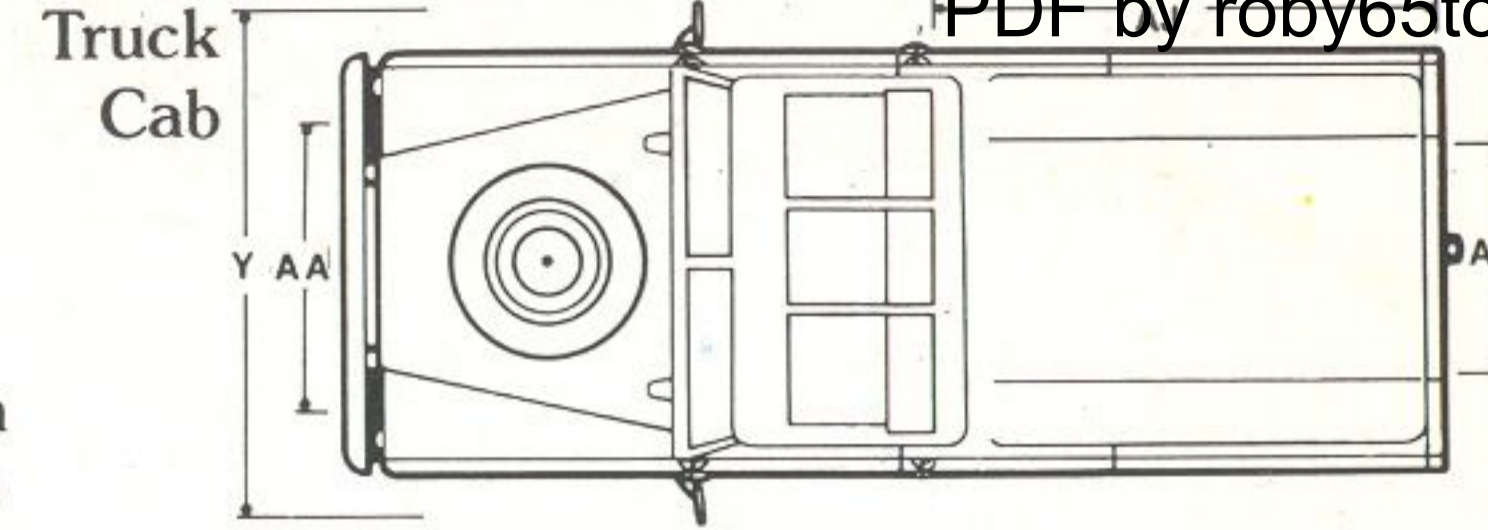

Truck Cab

Dimensions	109 in. Wheelbase Truck Cab		109 in. Wheelbase 10 & 12 Seater Station Wagon		109 in. Wheelbase Truck Cab		109 in. Wheelbase 10 & 12 Seater Station Wagon	
	mm.	in.	mm.	in.	mm.	in.	mm.	in.
Seat Headroom	A	0991	39 00	0991	39 00	AE	0495	19 50
Wheelbase	W	2768	109 00	2768	109 00	AE	0495	19 50
Overall Height (Unladen)	X	192	75 50	2010	79 00	AF	0914	36 00
Overall Width (excl. mirrors)	Y	1690	66 54	1690	66 54	AF	0914	36 00
Overall Length	Z	4445	175 00	4445	175 00	AJ	1850	72 75
Height - Body Floor to Roof	AC	-	-	1187	46 75	AJ	0762	30 00
Body Interior Width	AD	1460	57 48	1460	57 48	AH	0209	8 25
Track	AA	1334	52 52	1334	52 52	AH	0209	8 25
Rear Door Opening Height							14300	47ft
Body Interior Height								
Rear Door Opening Width								
Tailgate Opening Width								
Body Interior Length (*without spare wheel fitted)								
Height of Body Floor (unladen)								
Ground Clearance								
Turning circle								

109 V8 Technical Specification

Engine
 Type O.H.V. all aluminium
 Bore 88.9mm (3.5in)
 Stroke 71.1mm (2.8in)
 Capacity 3528cm³
 Compression ratio 8.13:1
 Max. power 92 P.S. (DIN) @ 3,500rpm 67.7kW (90.7bhp)
 Max. torque 23mkg (DIN) @ 2,000rpm 225.6Nm (166.4lbfft)
 Max. r.p.m. 5,000
 Firing order 1, 8, 4, 3, 6, 5, 7, 2

Lubrication
 Nominal pressure 2.1-2.8kgf/cm² (30-40lb/in²) @ 2,400
 Oil filters - internal Gauze pump-intake strainer
 - external Full flow oil filter

Fuel System
 Carburettors Twin Zenith-Stromberg
 Petrol pump Facet electric
 Fuel tank At rear of vehicle

Cooling System
 Type Pressurised with pump, fan, thermostat and expansion tank
 Working pressure 1.05kgf/cm² (15lb/in²)
 Thermostat Wax type 82°C
 Radiator Crossflow

Transmission
 Clutch Diaphragm spring single dry plate 267mm (10.5in) dia.
 Main gearbox Four speed and reverse. Synchronesh on forward gears
 Transfer box Two speed reduction on main gearbox output. Front and rear drive permanently engaged via a third differential - locked by a vacuum control switch. Switch mounted on heelboard.

Overall ratios - final drive

High range - Top	4.7281:1
Third	7.1154:1
Second	11.5745:1
First	19.2390:1
Reverse	17.3253:1
Low range - Top	11.7497:1
Third	17.6822:1
Second	28.7634:1
First	47.8101:1
Reverse	43.0538:1
Differential ratio (both axles)	3.54:1

Front axle Spiral bevel with enclosed constant velocity joints

Brakes
 Type Hydraulic - servo assisted
 Drum diameter 279.4mm (11.00in)
 Brake shoe width 76.2mm (3.00in) front, 57.1mm (2.25in) rear
 Handbrake Mechanical duo-servo drum brake on rear of transfer box
 Size 184mm (7.25in) dia., 76mm (3.00in) width

Wheels
 Type Ventilated disc
 Size 5.50Fx16ins
 Tyre size 7.50x16ins

Electrical
 Type 12 volt negative earth
 Battery 58 Ah
 Ignition Ballasted coil
 Alternator 18 ACR - 45 amp
 Starter motor Pre-engaged type

Capacities
 Engine oil (inc. filter) 5.96 litres (17pt)
 Main gearbox 2.6 litres (4.5 pt)
 Transfer box 3.1 litres (5.5 pt)
 Rear differential 2.6 litres (4.5 pt)
 Front differential 1.53 litres (2.7pt)
 Fuel tank 68.25 litres (15gal)
 Cooling system 9.66 litres (17pt)

Maximum Permissible Towed Weights

	On-Road	Off-Road
Trailer with brakes	500kg (1,100lb)	500kg (1,100lb)
Trailer with overrun brakes	2,000kg (4,400lb)	1,000kg (2,200lb)
4-wheel trailers with coupled brakes	4,000kg (8,800lb)	1,000kg (2,200lb)

Vehicle Weights
 Truck cab 2710kg
 Station wagon 2710kg
 For sustained cross country use the Gross Vehicle Weight must be reduced by 90kg (off the rear axle).

Rear axle Propeller shafts
 Hypoid with fully floating shafts
 Open type - front propshaft with double Hookes joint at gearbox end

Steering
 Type Recirculating ball, worm and nut
 Lock to lock 3.5 turns
 Steering damper Fitted to drag link



Land Rover Ltd Lode Lane, Solihull, West Midlands
 B92 8NW, England



SUPERCOVER
 Even if you never need it,
 it's good to know you've got it.
 Applicable only to vehicles used within the United Kingdom

Lit No. LR / 139 / B - 80 / 25m